

Features

- ◆ 15 circuits models
- ◆ Speed up to 100 rpm continuous
- ◆ Gold-Gold contacts
- ◆ 250mm standard lead lengths
- ◆ Compatible with data bus protocols
- ◆ Sealed units are available
- ◆ Flexible, color-coded, silver-plated, lead wires
- ◆ Precision ball bearings meet or exceed life requirements for most commercial applications

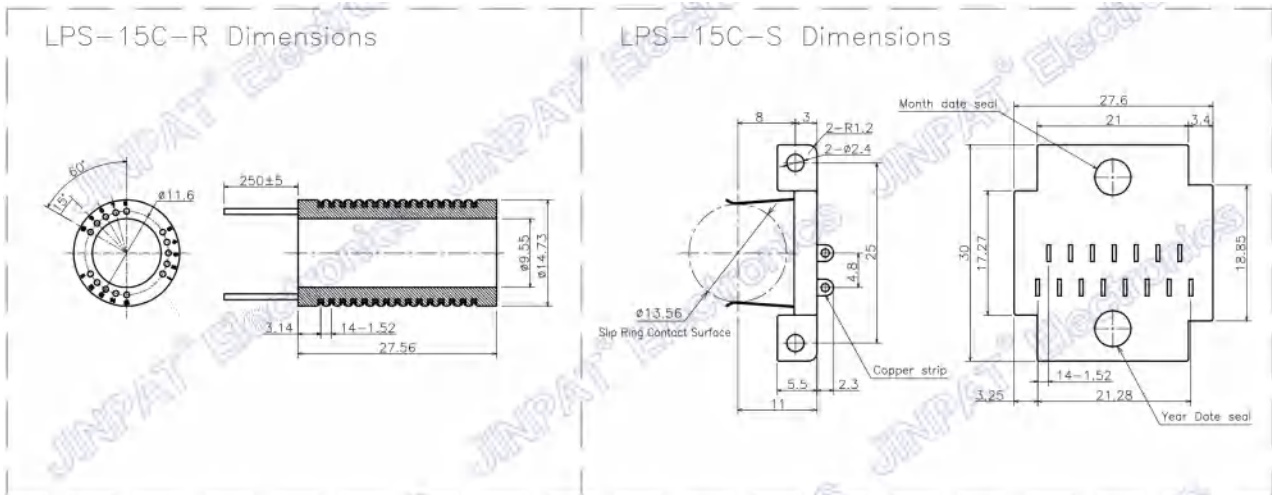
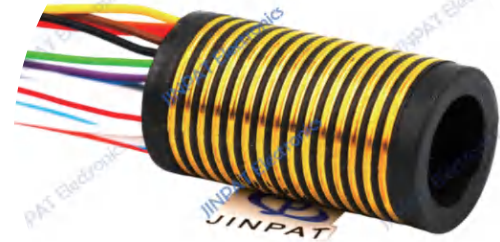

Electronic & Electric			Mechanical	
Circuits	Total	15CKT	Working Speed	0~100rpm
	Detail	15x2A	Contact Material	Gold to Gold
Rating Voltage		240V AC/DC	Housing Material	Engineering plastics
Dielectric Strength		≥500VAC@50Hz	Lead Wire Length	Stator:250±5mm Rotor:Copper strip
Insulation Resistance		≥100MΩ@500VDC	Electrical Noise	<35mΩ(Operate at 5 rpm)
Environment			Remarks	
Working Temperature		-20°C~+60°C	Application	/
Working Humidity		≤60%RH	Other	/
IP		IP00	Note: "P" stands for power, "S" stands for signal.	